

## Backwater lifting station Ecolift DN 100, Floor slab, tileable

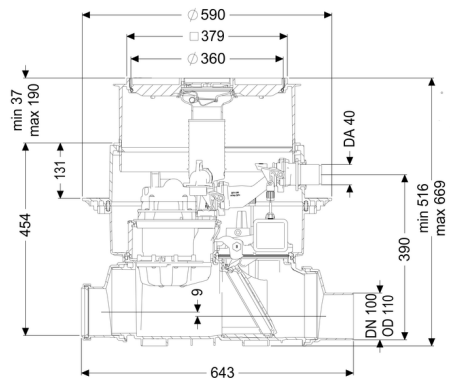

### Article information

Item no.: 21100X  
 GTIN: 4026092046845  
 Price group: 20

### Advantages

- Hybrid function: uses the natural fall to the sewer - pump is only used in case of backwater
- Quiet and energy-saving
- Double safety due to backwater flap and pressure pipe

### Description

The backwater lifting station for faecal and non-faecal wastewater is equipped with one pump and one motor-driven closure system.

The pipe cross-section is normally open and the water drains to the sewer via natural fall. Backwater is detected by an optical probe, which causes the motor-driven closure system to close automatically. During the backwater phase, the water drains via a pressure pipe, which carries the wastewater above the backwater level and into the sewer.

Connection hole in the drain body for installation in the ground, incl. seal for pressure pipe and cable conduit.

The station is controlled by a user-friendly control unit, which is optionally integrated in the building management system via a potential-free contact, or alarm and collective fault messages can be output via a GSM interface.

Type of wastewater: wastewater with sewage  
 Installation situation: floor slab installation

### Version:

Odour trap: Multistop  
 Emergency closure: yes

|   |  |
|---|--|
| Pump control:                           | Control unit   |
| Passage seal for conduit pipe (DN):     | 50 mm  |
| Delivery state:                         | Pre-mounted for final assembly on site (pumps and sensor system must be fitted on site and control unit must be connected) |
| Number of motor-driven backwater flaps: | 1  |

#### General characteristics:

|                      |            |
|----------------------|------------|
| Nominal size (DN):   | 100        |
| Outer diameter (OD): | 110        |
| Colour:              | black      |
| Approval:            | Z-53.2-487 |

#### Dimensions:

|                           |        |
|---------------------------|--------|
| Length:                   | 642 mm |
| Width:                    | 590 mm |
| Cutout dimension, length: | 750 mm |
| Cutout dimension, width:  | 750 mm |

#### Tank:

|  |              |
|--|--------------|
| Pressure pipe connection (OD):                         | 40 mm        |
| Installation depth:                                    | 486 - 640 mm |
| Groundwater resistant from lower edge of base section: | 3,000 mm     |
| Nominal pressure (PN):                                 | 6            |

#### Drain body:

|                      |                                     |
|----------------------|-------------------------------------|
| Socket version:      | including spigot and socket         |
| Vertical adjustment: | vertically adjustable upper section |

#### Coverage features:

|                       |                      |
|-----------------------|----------------------|
| Type of cover:        | tileable cover plate |
| Cover material:       | Polymer              |
| Drainage function:    | yes                  |
| Max. flooring height: | 16 mm                |
| Load class:           | K 3 (EN 1253-1)      |
| Length:               | 366 mm               |
| Width:                | 366 mm               |

Locking: Lock & Lift

### Pumping device:

|  |                                |
|--|--------------------------------|
| Pump:  | SPZ 1000                       |
| Number of pumps:                                   | 1                              |
| Max. pumping capacity:                             | 11.5 m <sup>3</sup> /h         |
| Max. pumping height:                               | 10 m                           |
| Operating mode:                                    | S3 - 50 %                      |
| Power P1:  | 1.2 kW                         |
| Power P2:  | 0.69 kW                        |
| Speed:   | 2,800 U/min                    |
| Type of fuse required (electrical protection):     | C 16 A                         |
| Max. temperature (permanent) of conveyed material: | 40 °C                          |
| Connection type:                                   | coded plug                     |
| Weight:  | 10 kg                          |
| Impeller type:                                     | Macerator                      |
| Length of mains cable for pump:                    | 5 m                            |
| Rated current:                                     | 5.2 A                          |
| Protection class (pump):                           | IP 68 (3m/48h)                 |
| Protection class:                                  | I                              |
| Type of pump connection cable:                     | H07RN-F 3G 1.0 mm <sup>2</sup> |
| Temperature monitoring:                            | integrated                     |
| Cos phi - power factor:                            | 0.97                           |
| Insulation class:                                  | F                              |
| Vertical drop between inlet and outlet:            | 9 mm                           |
| Motor type:  | KSM 140                        |
| Protection class motor:                            | IP 68 (3m/48h)                 |
| Protection class probe:                            | IP 68 (3m/48h)                 |

### Control:

|   |               |
|---|---------------|
| Control unit:                           | Comfort       |
| Operating voltage:                      | 230 V         |
| Mains frequency:                        | 50 Hz         |
| Self-diagnosis system (SDS):            | yes           |
| Battery buffering:                      | yes           |
| Multi-line display:                     | yes           |
| Log book function:                      | yes           |
| USB interface:                          | no            |
| GSM interface:                          | no            |
| Potential-free contact:                 | yes           |
| Standby power:                          | 5 W           |
| Protection class control unit:          | IP 54         |
| Length of mains cable for control unit: | 1.4 m         |
| Type of level measurement:              | optical       |
| Level measurement instrument:           | optical probe |

Alarm sensor:

optical probe