

Pumping station Aquapump Small Duo, Basic, GTF 1250

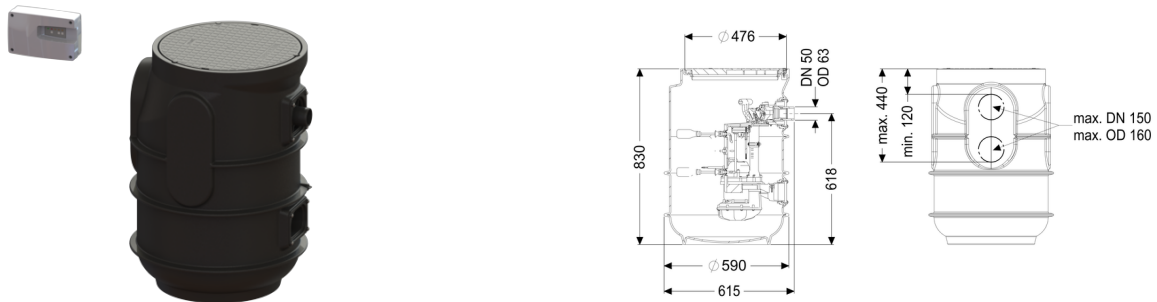

Article information

Item no.: 828851
 GTIN: 4026092093009
 Price group: 20

Advantages

- Including backflow preventer for the pressure pipe
- Including openings for inlet, ventilation and cable duct
- With pedestrian class polymer cover plate

Description

The pumping station for faecal wastewater is suitable for underground installation and is equipped with a backflow preventer for the pressure pipe. The PE tank is resistant to domestic wastewater and includes a pedestrian class polymer cover plate. The pump with multi-vane impeller ensures maximum operating reliability. The components are pre-assembled for final assembly on site. Including openings for inlet.

- tank made of PE, resistant to domestic wastewater
- with a pedestrian class cover plate made of polymer
- including backflow preventer for the pressure pipe
- including openings for inlet, ventilation and cable duct
- pump/s with multi-vane impeller for maximum operating reliability

Type of wastewater: wastewater without sewage
 Installation situation: underground installation

Version:

Type of system: Twin pump station
 Installation: Wet installation
 Pump control: Control unit
 Backflow preventer: integrated

Delivery state: Pre-mounted for final assembly on site (pumps and sensor system must be fitted on site and control unit must be connected)

General characteristics:

Colour: black
Standard: EN 12050-2

Dimensions:

Length: 590 mm
Width: 590 mm
Height: 830 mm

Tank:

Inlet max. scoring (DN): 100 mm
Pumping volume: 60 l
Pressure pipe connection (DN): 50 mm
Pressure pipe connection (OD): 63 mm
Installation depth: 830 mm

Coverage features:

Type of cover: Round cover plate
Colour of cover: black
Length: 615 mm
Width: 600 mm
Locking: lockable

Free passage: 30 mm

Pumping device:

Pump: GTF 1250
Number of pumps: 2
Max. pumping capacity: 20 m³/h
Max. pumping height: 11 m
Operating voltage: 230 V
Mains frequency: 50 Hz
Operating mode: S1
Power P1: 1.3 kW
Power P2: 0.8 kW
Speed: 2,700 U/min
Type of fuse required (electrical protection): C 16 A

Max. temperature (permanent) of conveyed material:	40 °C
Connection type:	coded plug
Weight:	10 kg
Impeller type:	Multi-vane impeller
Length of mains cable for pump:	10 m
Rated current:	5.4 A
Protection class:	I
Type of pump connection cable:	H07RN-F 3G 1.0 mm ²
Temperature monitoring:	integrated
null:	260 mm
null:	160 mm
Insulation class:	F

Control:

Control unit:	Basic
Operating voltage:	230 V
Mains frequency:	50 Hz
Self-diagnosis system (SDS):	yes
Battery buffering:	yes
Potential-free contact:	optional
Motor protection switch:	yes
Protection class control unit:	IP 54
Connection type:	Schuko (earthed contact) 2-pin
Length of mains cable for control unit:	1.45 m
Type of level measurement:	mechanical
Alarm sensor:	Float switch