

Pumping station Aquapump XXL Duo, STZ 5200-S1

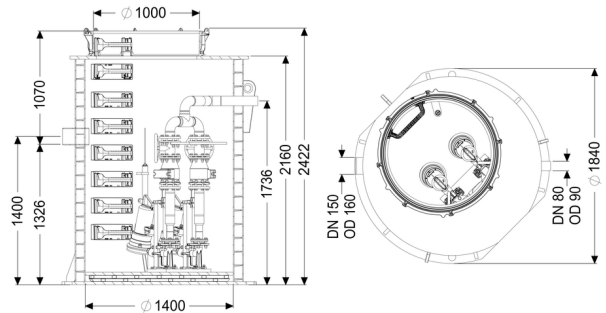

Article information

Item no.: 8743040
 GTIN: 4026092078082
 Price group: 60

Description

Type of wastewater: wastewater with sewage
 Installation situation: underground installation

Version:

Type of system: Twin pump station
 Installation: Wet installation
 Shut-off valve: Shut-off valve made of cast iron
 Pump control: Control unit
 Backflow preventer: integrated
 Access steps: yes
 Note on installation depth: in combination with a chamber module
 Passage seal for ventilation pipe (DN): 100 mm
 Passage seal for conduit pipe (DN): 100 mm

Delivery state: Pre-mounted for final assembly on site (pumps and sensor system must be fitted on site and control unit must be connected)

General characteristics:

Colour: black
 Standard: EN 12050-1

Dimensions:

Length:	1,880 mm
Width:	1,880 mm
Height:	2,440 mm

Tank:

Number of inlets:	1 ST
Inlet nominal size (DN):	150
Inlet nominal size (OD):	160 mm
Distance pipe bottom inlet to tank bottom:	1,320 mm
Distance from centre of outlet pipe to tank bottom:	1,735 mm
Distance from centre of inlet pipe to tank bottom:	1,400 mm
Pumping volume:	800 l
Pressure pipe connection:	horizontal
Pressure pipe connection (DN):	80 mm
Pressure pipe connection (OD):	90 mm
Groundwater resistant from lower edge of base section:	3,000 mm
Clear width of tank (LW):	1,600 mm
Clear width of entry (LW):	1,000 mm
Chamber system:	Twin walled re-enforced pipe chamber

Pumping device:

Pump:	STZ 5200
Number of pumps:	2
Max. pumping capacity:	21.3 m ³ /h
Max. pumping height:	52 m
Operating mode:	S1
Power P1:	5.2 kW
Power P2:	4.4 kW
Speed:	2,840 U/min
Max. temperature (permanent) of conveyed material:	40 °C
Connection type:	Direct connection
Weight:	56 kg
Impeller type:	Macerator
Length of mains cable for pump:	10 m
Rated current:	8.7 A
Protection class (pump):	IP 68 (20m)
Protection class:	I
Type of pump connection cable:	H07RN8-F PLU 10G 1.5 mm ²
Temperature monitoring:	integrated
Cos phi - power factor:	0.89

Insulation class: H

Control:

Control unit:	Comfort Plus
Operating voltage:	400 V
Mains frequency:	50 Hz
Self-diagnosis system (SDS):	yes
Battery buffering:	yes
Multi-line display:	yes
Log book function:	yes
USB interface:	yes
GSM interface:	yes
Potential-free contact:	yes
Type of fuse required (electrical protection):	3 x C 32 A
Motor protection switch:	yes
Protection class control unit:	IP 54
Length of mains cable for control unit:	0 m
Type of level measurement:	hydrostatic
Level measurement instrument:	Level sensor
Alarm sensor:	Level sensor